



Wet Abrasive Blasting Systems

„Manual“
torbo[®] LOC
1/2001 english

Contents

Code of Practice	5
Data of the Machine.....	5
1. Basic Instructions.....	6
2. Basic Safety Instructions	7
1. Instructions for Operation.....	10
1.1. Connections.....	10
1.2. Components for Operation	11
1.3. Instructions for Transport.....	12
2. Operating Instructions.....	13
2.1. Connecting the Machine	13
2.2. Normal Operation	14
2.2.1. Filling the machine	14
2.2.2. Setting up the machine	15
2.2.3. Operating with electric Remote control.....	16
2.3. Switching off the Machine.....	17
2.4. Frost precaution in winter	18
3. Information for Practice.....	19
3.1. Blasting result – optimization of the parameter	19
3.1.1. Soft blasting	19
3.1.2. Power blasting	19
3.2. Adjustments and settings	19
3.3. Blasting nozzle and operating.....	21
4. Maintenance	22
4.1. Maintenance work	22
4.2. Information to the weekly maintenance.....	23
5. Trouble-shooting.....	24
6. Technical Data.....	26
6.1. General Data	26
6.2. Wiring scheme	27
6.3. Hydraulic (water) scheme	28
6.4. Pneumatic scheme	29
Headword contents.....	31

Code of Practice

(extract from the Instructions for Operation)

It must always be adhered to the rules and regulations valid for wet abrasive blasting and also to the valid rules and regulations for the prevention of accidents to be applied to the respective field of application; special attention must be paid to the following:

- Any and all recommendations and instructions, in particular the basic safety instructions included in the instructions for operation !
- The machine must be operated by trained and skilled personnel only !
- The blasting lance should never be directed towards persons and/or animals !
- The magnetic clamp of the remote control must always be securely fixed at the wrist !
- Helmet, hearing- and breathing protection apparatus must always be worn !
- Protective clothing must always be worn !
- Before putting into operation make sure that the machine and its accessories are in perfect condition.
- The control cabinet of the machine must be opened only for adjustments, inspections or maintenance work.
- A regular maintenance of the machine is strongly recommended.
- The compressor must always be operated without tool lubricator.

Data of the Machine

1. Basic Instructions

Instructions for application of the manual

A fundamental prerequisite for the safe and troublefree operation of this machine is the knowledge of the basic safety rules, regulations and instructions.

The manual includes the essential instructions for a safe operation of the machine.

The manual and in particular the safety instructions must be adhered to by all persons operating the machine.

Moreover, the instructions for the prevention of accidents during blasting as well as the rules and regulations for the prevention of accidents valid on site must be adhered to.

Duties of the operator and of the personnel

The operator is obliged to have operated the machine only by those persons, who

- are familiar with the basic regulations for safety at work and for the prevention of accidents and who have been adequately instructed and trained for the operation of the machine and
- have read, understood and confirmed by their signature the content of the chapter on safety and the respective caution notes.
- At regular intervals, it has to be checked whether the safety instructions are adhered to by the personnel.

Before starting to work, all persons authorized to operate the machine shall commit themselves to

- strictly adhere to the basic rules and regulations regarding safety at work and prevention of accidents;
- read the chapter on safety and the caution notes in this manual and to confirm by their signature to have understood same.

Dangers in operating the machine

The torbo wet abrasive blasting machine has been designed in accordance with the latest state of the art and in conformity with the approved safety requirements. In spite of that, the use of the machine may entail dangers to life and limb of the user or third parties resp. impairments for the machine or other material assets.

The machine must be operated only

- in a safe and perfect operating condition and
- for use to the intended purpose.

Any troubles which might impair the operational safety, must be eliminated immediately.

Usage to the intended purpose

The torbo wet abrasive blasting machine has been designed exclusively for surface treatment of natural and artificial stones, ferrous and non-ferrous metals, wood and similar materials by the wet abrasive blasting process using blasting media and water.

Any other or exceeding use is not regarded as in conformity with the intended purpose. Messrs. torbo Engineering Keizers GmbH shall not be liable for any damages arising from such inappropriate use.

The 'usage to the intended purpose' also implies:

- the adherence to all instructions of the manual and
- the proper performance of all inspection and maintenance work.

Please also take into consideration that a loss of material of the various types of surfaces as well as a deformation or breakage of objects by wet abrasive blasting (in particular in case of wet abrasive blasting using hard and sharp-edged blasting media and a high jet pressure on thin sheet material and glass panes) cannot be excluded.

As blasting media all conventional and commercially available blasting media are suitable which are heavier than water and which, by the addition of water, do not lump or emit hazardous vapours or gases and which are approved for wet abrasive blasting on the surface to be treated.

Warranty and liability

On principle, our "General Conditions for Sale and Delivery" shall apply which will be at disposal upon conclusion of the contract at the latest.

Warranty and liability claims in case of personal injury and damage to property are excluded if they are due to one or several of the reasons mentioned hereunder:

- usage of the machine not in conformity with the intended purpose;
- improper putting into operation, operation, maintenance and assembly of the machine;
- operation of the machine with defective or not properly fitted and/or not operational safety devices and protective guards;
- non-adherence to the advice and instructions of the manual regarding transport, storage, assembly, putting into operation, operation, maintenance and setting of the machine;
- unauthorized and/or improper alterations of the machine design;
- inappropriate control of machine- and wearing parts;
- improper performance of maintenance or repair;

- accidents by the influence of foreign matter or Force Majeure.

Copyright

The copyright regarding this manual remains with Messrs. torbo ENGINEERING KEIZERS GmbH, D-46325 Borken. This manual is intended exclusively for use by the operator and its personnel. It contains instructions and advice which - neither wholly nor partly - may be copied, divulged or otherwise disclosed. Any infringement may entail criminal prosecution.

2. Basic Safety Instructions

Definition of symbols and references

In this manual, the following symbols and definitions of dangers are used:



Danger !

This symbol defines an **imminent danger** for life and health of persons. The non-adherence to these instructions will entail severe effects detrimental to health and even highly dangerous injuries.



Warning

This symbol defines a **possible danger** for life and health of persons. The non-adherence to these instructions may entail severe effects detrimental to health and even highly dangerous injuries.



Caution

This symbol defines a situation which **might become dangerous**. The non-adherence to these instructions may entail slight injuries or damages to property.



This symbol means essential instructions for a proper handling of the machine. The non-adherence to these instructions may entail troubles at the machine or in the environment.



This symbol refers to hints and recommendations for use and in particular to useful information. They will help you to make an optimal use of all functions of the machine.

Organizational measures

The operator is obliged to place at disposal the required personal protective outfit (e.g. hearing- and breathing apparatus and face guards). The available protective and safety equipment must be checked at regular intervals.

Safety devices

be properly installed and operable. Protective devices, guards etc. may be removed only at standstill of the depressurized machine which has been secured against re-start.

Informal safety measures

The manual forms part of the machine and has always to be kept on site. Apart from the manual, the rules and regulations for the prevention of accidents during abrasive blasting as well as the locally valid rules and regulations for the prevention of accidents and for environmental protection must always be at disposal and adhered to. It must be ensured that the safety instructions and warning boards at the machine are always legible.

Training of the personnel

The machine must be operated resp. put into operation only by trained and instructed personnel. Untrained personnel or personnel to be trained and instructed may operate the machine only under the supervision of experienced and skilled persons. The competence with regard to putting into operation, operating, maintenance, assembly, setting and repair must be clearly stipulated.

Safety measures under normal service conditions

In normal operation of the blasting machine, the following points must be observed:

The machine must be put into operation only if:

- all protective devices are fully operable,
- all connections have been made and secured,
- the magnetic clamp of the remote control has been fixed at the wrist of the operator and does not contact the remote control and, if the operator keeps a firm hold on the manual blasting nozzle/lance.
- Before switching on or starting the machine it must be made sure that nobody can be jeopardized hereby.
- At least once per shift, the machine and its equipment must be checked for externally visible damages.



Danger !

- The blasting lance must never be directed to persons and/or animals !
- Never direct the blasting lance to objects which are not to be subject to surface treatment.
- The inspection of the machine also includes its equipment.

Dangers due to electric energy

- If works have to be performed at the electric supply system, this must be done by a skilled electrician only.
- The electric equipment of the machine must be checked at regular intervals. Loose connections and scorched cables must be eliminated immediately.
- The control cabinet must always be kept closed. Authorized personnel only shall have access to the control cabinet using a key or adequate tool.
 - When working at live parts, a second person must assist who in case of need could actuate the main switch.

Dangers due to pneumatic energy

- Pneumatic equipment must be operated only by personnel disposing of special knowledge and experience in the field of pneumatics.
- Before tackling any repair work, sections of the pneumatic system and delivery conducts to be opened must be depressurized.
- At reasonable intervals, pneumatic hose pipes are to be exchanged even if no deficiencies impairing the safety are visible.

Special hazards

When operating the machine, special attention has to be paid to the following in order to avoid hazards:

- Never direct the blasting nozzle towards persons and/or animals !
- The blasting nozzle must not be directed towards objects which are not allowed to be blasted !
- Keep a tight hold on the blasting lance during start (back kick of the blasting lance!)
- Unauthorized starting of the machine in case of interruptions (also short interruptions) must be avoided.
- Machine to be made inaccessible for unauthorized people. Blasting nozzle and remote control to be made inaccessible for unauthorized people.
- During interruptions, magnetic clamp of the remote control to be put into jacket- or trouser pocket.
- When operating the machine, the control cabinet must be kept closed and made inaccessible for unauthorized people.

Dangers due to superfines as well as noxious gases and vapours

The concentration of fine dusts during operation of the machine is detrimental to health. The operators therefore have to be protected by an adequate protective outfit or protective measures against inhalation of superfines.

The addition of chemical or other agents must be clarified with the producer and/or supplier of the agents. If on account of these agents or by using these agents in combination with water and/or blasting media health risks should arise, adequate protective measures must be taken.

If by the use of these agents the functions of the machine should be impaired, a written confirmation must be obtained from torbo Engineering Keizers GmbH, D-46325 Borcken, before using such agents.



Warning

- Adequate breathing protection is to be ensured when working on the machine.
- Adhere to the instructions of the producer when using other substances than water and/or commercially available blasting media.

Dangers due to the noise of the machine

During the operation of the machine, the continuous sound intensity level depending on the setting amounts to 105 dB(A) which might be higher on account of unfavourable local conditions.

The operating staff must be protected by an adequate outfit or protective measures against impairment of hearing.



Warning

- Adequate hearing protection is to be ensured when working on the machine.

Maintenance, repair, trouble-shooting

Regarding maintenance, repair and trouble-shooting the following requirements must be fulfilled:

- The specified maintenance and inspection work must be carried through according to schedule.
- The operating staff must be informed in time of any intended maintenance and/or repair.
- All plants, systems, machines, appliances upstream and downstream of the wet abrasive blasting machine, as well as all supply systems like current, compressed air and pressurized water are to be secured against accidental actuation.
- For all maintenance-, inspection- and repair works, the machine must be de-energized and depressurized and secured against re-start,
attach warning board to prevent from restarting the machine;
uncouple compressed-air- and pressurized-water hoses from the machine;
disconnect cable from power source.
- After completion of the works check loosened screws and connections for tight fitting.
- After completion of the works check all safety devices for correct functioning.

Alterations of the machine design

No alterations, attachments or conversions of the machine are allowed without the approval of the manufacturer.

All conversion measures are subject to the written approval of Messrs. torbo Engineering Keizers GmbH, D-46325 Borken.

Any machine parts which are not in a perfect state and condition, must be exchanged immediately.

Only original spare- and wear parts are to be used as in case of parts bought elsewhere it cannot be warranted that they have been designed and manufactured to fulfil the requirements regarding quality and safety.

Disposal of substances/materials and cleaning of machine

All substances and materials used have to be properly handled and disposed of. In particular, this applies to:

- Blasting media and water used in the performance of any works and jobs,
- Additives used, like e.g. rust retarding agents, solvents for cleaning the machine etc.

1. Instructions for Operation

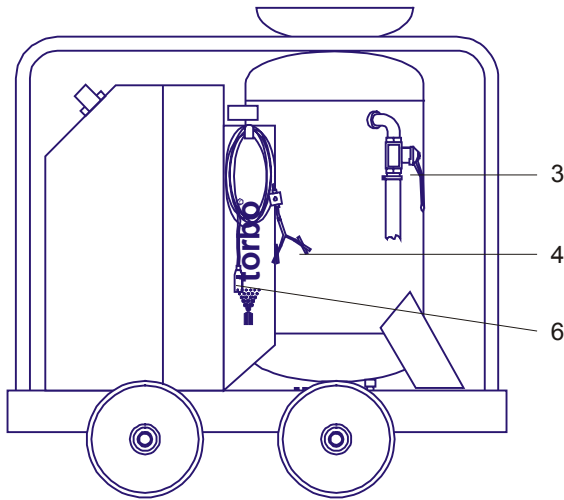

Chapt. 1, Figure 1: connections (part 1)

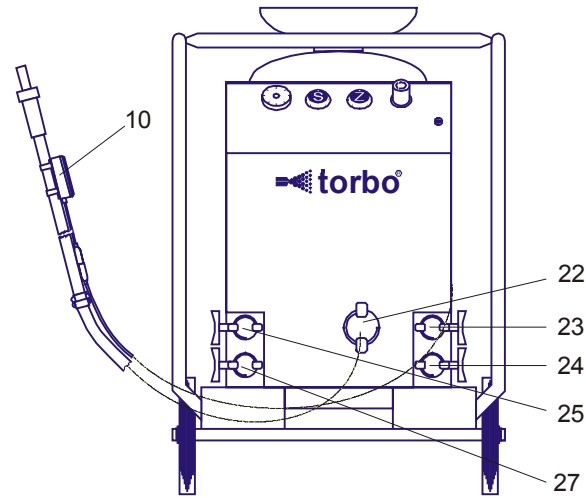

Chapt. 1, Figure 2: connections (part 2)

1.1. Connections



Warning

- The technical data and requirements to be fulfilled by compressed-air hoses may be taken from the technical specification (look at chapter 6);
- Hoses and cable are to be checked for wear and damage and exchanged, if necessary;
- Couplings of compressed-air hoses must always be secured against loosening.

Compressed-air supply (25 & 27): Connect compressor on compressed air-connection 1 (25) for gentle cleaning and on compressed air-connection 1 (25) and 2 (27) for pwer blasting. The compressed-air hose size should be at least 1“.



- If the compressor is provided with a tool oiler, this must be closed !
- Use only clean pressure hoses, it will reduce the maintenance work.



- It is essential that the hose between compressor and machine has got a sufficiently large cross-section (look at chapter 3).

Blasting hose connection (22): The cross-section and the length of the blasting hose must be adapted to the work to be performed and to the compressed-air supply connected (look at chapter 3).



Caution

- The longer the blasting hose and the higher the blasting pressure and the smaller the cross-section of the blasting hose, the longer the delay of the turn off at the nozzle.

Water supply (23) and Wasser outlet (24): Make sure that the machine is connected to a correct water supply; connect upto 12 bar.



- Use only clean water and clean-up the water filter weekly, it will increase the service life of the pump.

Overflow port (3): This overflow has been designed to discharge excessive water when filling the machine, and after termination of the blasting, to relieve the pressure vessel from the hydraulic pressure.



- Use the torbo water tank 98 to re-use the water.

Power supply (4): The pole tongs have to be connected via the socket-outlet at the compressor or at any other 12V-D.C.-source so that black is connected to (-) and red to (+).



- If so, the diode at the socket-outlet is illuminated green.
- If the diode is red, the power supply to the machine is interrupted and the pole tongs must be reversed at the poles.

Connection of the remote control (6): Connect the remote control with extension cable on Coupling (6). The cable must be long enough to connect the remote control next to the blasting nozzle.



Warning

- Before connecting the electric remote control, the magnetic clamp must be fixed at the wrist of the operator and removed from the remote control !
- Use the small straps to fix the remote control at the blasting hose approx. 30 cm (12 Inch) behind the nozzle.



- look at chapter 3 for examples for the right election of the blasting hose.

1.2. Components for Operation

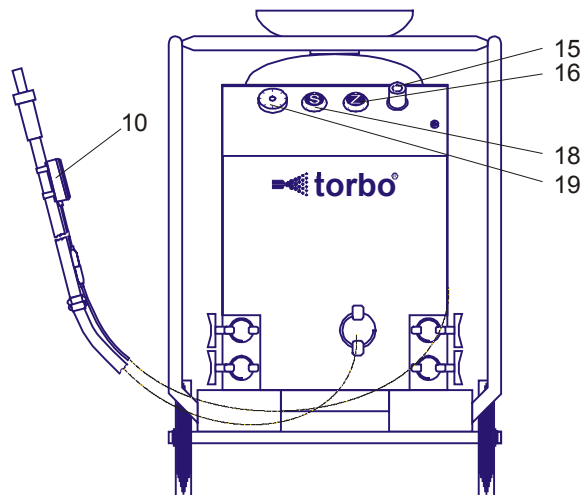

Chapt. 1, Figure 3: operating

Emergency-Switch (15): to turn off the machine in an emergency.

Extra Water dosage (16) – Equipment (506) and (507): To increase the water proportion in the blasting mixture. Setting is effected by rotation of handwheel „Z“ (2) with the figure on the scale in volume of water in litre per minute.



- The extra water reduces the power of the blasting media for softcleaning.
- Look also at blasting mixture dosage (3).



- To the clean the surfaces: Select extra water (handwheel „Z“ - 2) and set handwheel „S“ (3) on „0“

Blasting mixture dosage – handwheel „S“ (18): Setting is effected by rotation of handwheel with the figure on the scale in volume of blasting mixture in litre per minute.
(blasting mixture = 80% blasting media and 20% water).



- Find examples for the right blasting mixture consumption at chapter 3 and table chapter 3.2..
- Do not use too much blasting mixture to receive just a little more production because of creating otherwise too much waste and so too much cost for waste disposal and blasting media.

Blasting pressure control (19): For setting the blasting pressure at the machine. For softcleaning, turn the handwheel (19) to the left to reduce the maximum pressure. The max blasting pressure is restrict



- Examples for settings are shown in chapter 3 and table chapter 3.2.

Remote Control (10): For turn on and off the machine at the blasting nozzle.

For start blasting, put the magnet into the correct opening of the remote control and activate push button. To switch off, remove magnet from remote control.



Warning

- The magnet of the remote control must always be securely fixed at the wrist !
- Fix the remote control by means of the two straps approx. 30 cm (12 Inch) behind the nozzle holder on the grip of the blasting lance.

1.3. Instructions for Transport

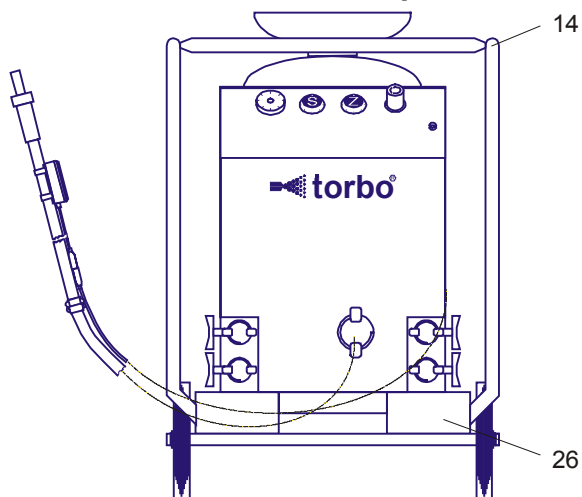

Chapt. 1, Figure 4: transporting



Caution

- For transporting it must be ensured that the pressure vessel is empty;
- The machine must be placed on a plane surface and is to be secured with wedges if necessary against slipping.
- During transport, the machine must be secured in conformity with the rules and regulations for the prevention of accidents applicable to the transport of piece goods.

The machine can be moved by traction or pushing of the framework (14).

In order to turn the machine is to be stepped with a foot into the opening (26), so that the machine stands only on one axis and can be driven around curves so.

To transporting the machine, Drive with a forklift in the openings (26).

2. Operating Instructions

2.1. Connecting the Machine

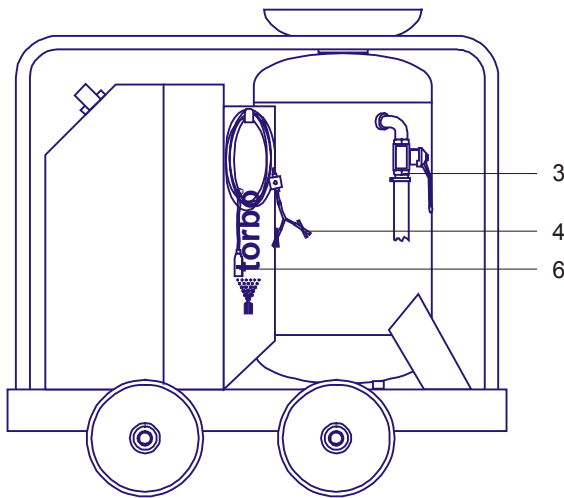

Chapt. 2, Figure 1: connecting (part 1)

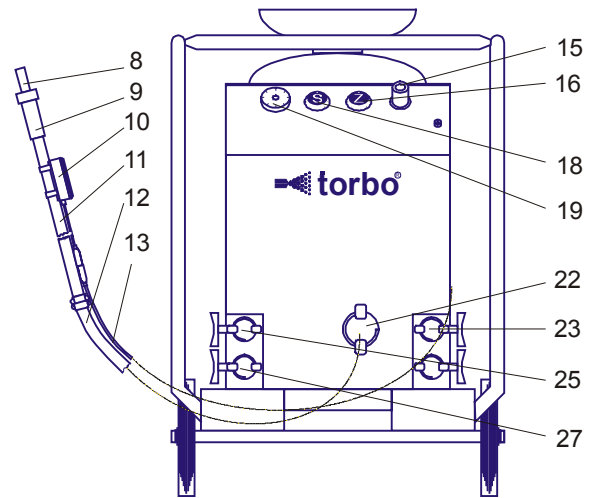

Chapt. 2, Figure 2: connecting (part 2)



- Read chapter 1.1. first for better understandability.

Connecting the machine as follows:

- Close handwheel (19) (turn left);
- Connect overflow hose at the overflow (3);
- Connect water hose on coupling (23);
- Connect compressed-air hose for gentle cleaning on coupling (25) or for power blasting on coupling (25) and (27).
- Connect pole tongs (4) on 12 Volt DC;
- Connect remote control (10) with extension-cable (13) on coupling (6);
- Connect the blasting lance (11) with extra blasting hose (12) on coupling (22);
- Screw the nozzle (8) into the nozzle holder (9) at the blasting lance (11);
- Fix remote control (10) approx. 30 cm (12 Inch) behind the nozzle holder (9) at the blasting lance (11);
- Check all connections for leakproofness.



Warning

- The magnet of the remote control must always be securely fixed at the wrist !
- Connections must always be secured against loosening.

2.2. Normal Operation

2.2.1. Filling the machine

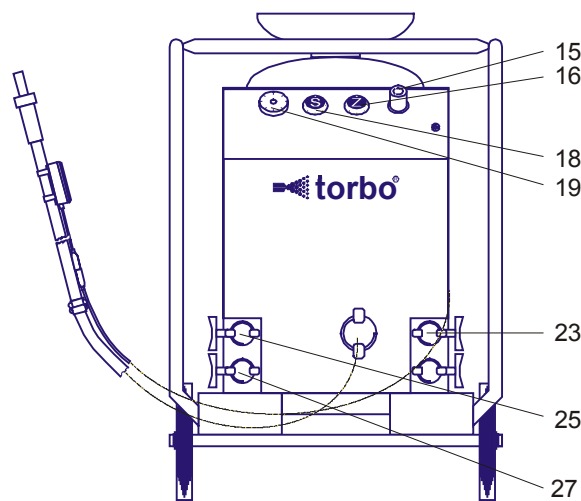
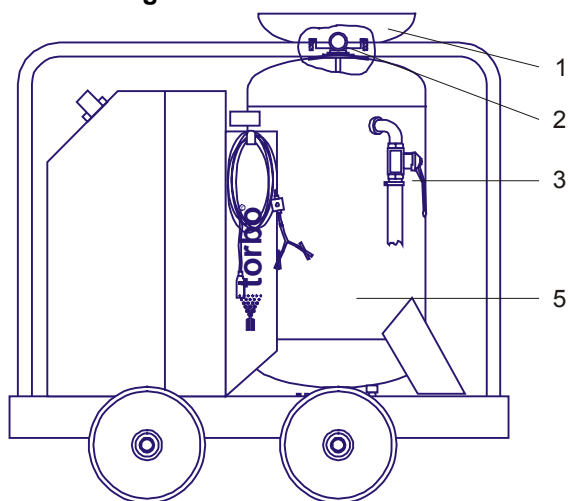

Chapt. 2, Figure 3: Normal operation (part 1)

Chapt. 2, Figure 4: Normal operation (part 2)



- Read chapter 1.2. first for better understandability.

A. First filling at location

Please proceed as follows:

- Select blasting media;
- Start air compressor and open compressed-air supply to the machine;
- Open water to the machine;
- Unlock EMERGENCY-OFF-switch (15);
- Open ball valve at overflow (3);
- Handwheel „S“ (18) to be set on position „D“ or on maximum value respectively;
- Fill blasting media through the sieve top (1) into the vessel (5) until blasting media penetrates from the overflow hose (3);
- Close ball valve on the overflow (3);
- Decreases sieve top (1); and wait until water penetrates on the top of the vessel (5);
- Pull up the vessel locking (2) by the ring until the pressure has built up;
- Place sieve top (1) back on the top of vessel.



- Filling of the vessel can be accelerated by the addition of water at the upper opening of the vessel and/or pushing the handwheel „S“ (18).

B. Repeating the filling

Please proceed as follows:

- Open ball valve on overflow (3);
- Handwheel „S“ (18) to be set on position „D“ or on maximum value respectively;
- Fill blasting media through the sieve top (1) into the vessel (5) until blasting media penetrates from the overflow hose (3);
- Close ball valve on the overflow (3);
- Decreases sieve top (1); and wait until water penetrates on the top of the vessel (5);
- Pull up the vessel locking (2) by the ring until the pressure has built up;
- Place sieve top (1) back on the top of vessel.



Warning

- When leaving the remote control unattended, the magnet must be secured so that the machine cannot be started by unauthorized people !

2.2.2. Setting up the machine

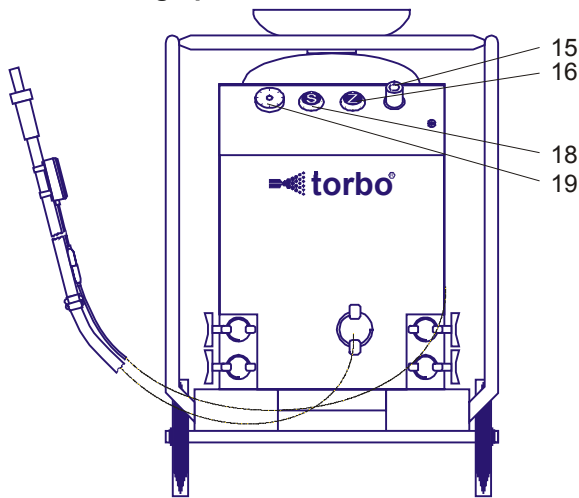

chapt. 2, Figure 5: Setting up the machine

When the machine is connected, the vessel is closed respectively the vessel pressure is adjusted, the machine has to be adjusted to the application; please proceed as follows:

- Set blasting media at handwheel „S“ (18);
- Set extra water at handwheel „Z“ (16), to increase the water-proportion in the blasting mixture (for soft cleaning);
- Set the blasting pressure at handwheel (19).



- To get more information about the correct setting to the respective application see chapter „**3. Information for Practice**“.
- If necessary, connect more blasting hose and extension cable and control and re-set the blasting pressure again.



- When more than 20 m (60 ft.) blasting hose are connected, check if the past-flow time is more than 1 second. If so, additionally the switch-off device QE99 has to be installed approx. 10 to 20 m (30 to 60 ft.) behind the blasting nozzle to reduce the past-flow time to less than 1 second.

2.2.3. Operating with electric Remote control

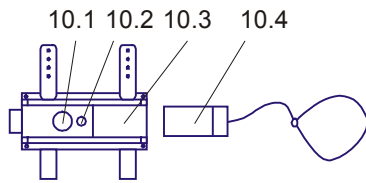

Chapt. 2, Figure 6: Operating with Remote control FB S99



- Read chapter 2.1. and 2.2.1. first for better understandability.

- Put magnet (10.4) on position (10.3) at the remote control (diode (10.2) illuminated);
- To start/blasting: Actuate push-button (10.1) at the remote control (diode (10.2) goes out);
- To switch off: Remove magnet (10.4) from remote control.

Each removing of the magnet stops blasting. To restart with blasting, put the magnet on position at the remote control and actuate push-button.



- Any and all recommendations and instructions, in particular the basic safety instructions, must be paid attention to !
- The blasting lance should never be directed towards persons and/or animals !
- The higher the blasting pressure is, the higher is the recoil at the nozzle.
- The longer the blasting hose is, the longer is the shut down time at the nozzle.



- Before starting read chapter 3. to find the right setting.
- If necessary, connect more blasting hose and extension cable and control the blasting pressure again.

2.3. Switching off the Machine

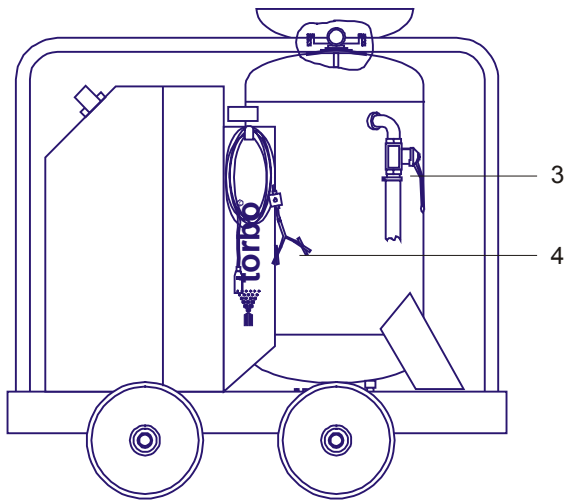

Chapt. 2, Figure 7: Switch off (part 1)

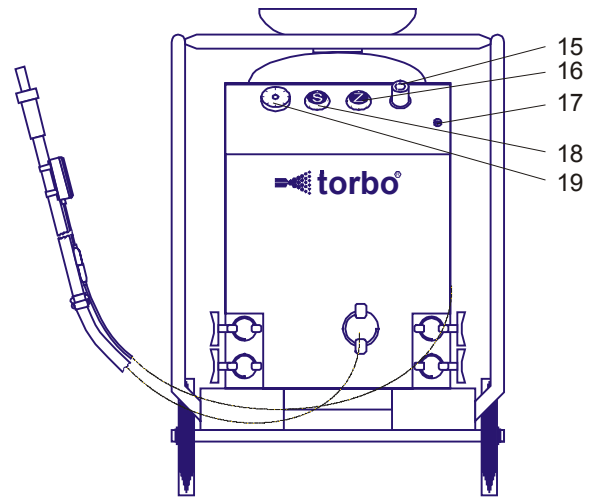

Chapt. 2, Figure 8: Switch off (part 2)

If there is a longer break after removing the magnet from the remote control (for example lunch), please proceed as follows:

- Open ball valve (3) at overflow;
- Interrupt compressed-air to the machine and switch off the compressor.

If there is a longer break (for example overnight), please proceed as follows:

- Close handwheel (19) (turn left);
- Uncouple pole tongs (4) or actuate EMERGENCY-OFF switch (15);
- Interrupt water feed to the machine;
- Empty the vessel;
- Push valve (17) until the pressure left out of the reserve tank;
- Uncouple Remote control and extension-cable, water hose, compressed air hose, blasting hose and save these.



Warning

- If necessary, the machine can also be switched off by using the EMERGENCY-OFF switch (15).

2.4. Frost precaution in winter

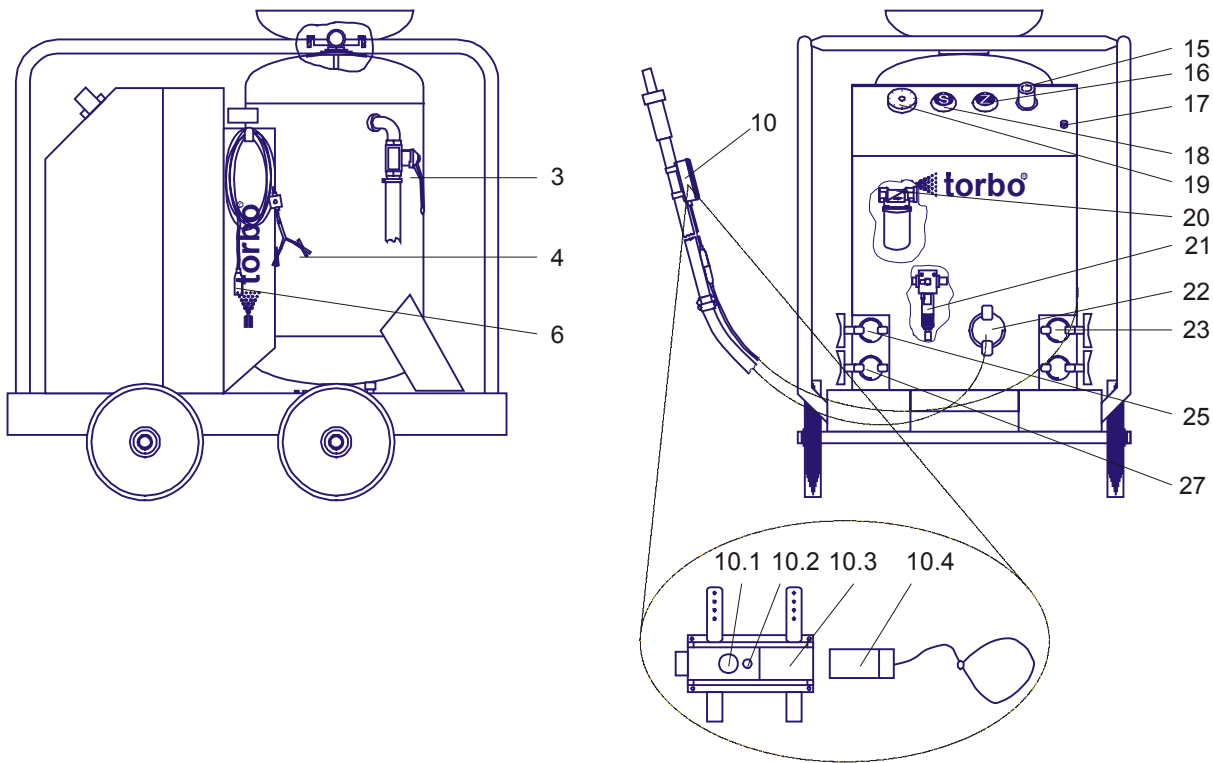

Chapt. 2, Figure 9: Frost precaution (part 1)

Chapt. 2, Figure 10: Frost precaution (part 2)

In order to protect the machine from damage by frost following steps must be made:

- Close handwheel (19) (turn left);
- If necessary, connect the hose between the vesselbottom and the control cabinet;
- Remove the filter element at the water filter (20);
- Connect compressed air hose on coupling (25 and/or 27);
- Connect pole tongs (4) on 12 Volt DC;
- Connect remote control (10) with cable on coupling (6);
- Connect blasting lance (11) with blasting hose on coupling (22);
- Fix remote control (10) approx. 30 cm (12 Inch) behind the nozzle holder at the blasting lance (11);
- Open ball valve at the overflow (3);
- Handwheel „S“ (18) and „Z“ (16) to be set on position „D“ or on maximum value respectively;
- If necessary, unlock EMERGENCY-OFF switch (15);
- Put magnet (10.4) on position (10.3) at the remote control (diode (10.2) illuminated);
- Actuate push-button (10.1) at the remote control (10) for starting (diode (10.2) goes out);
- Let the machine run for about 30 seconds and remove magnet (10.4) from remote control;
- Uncouple pole tongs (4) from 12 Volt DC;
- Uncouple remote control (10) and blasting lance (11);
- Open handweel (19) (turn right);
- Push valve (17) until the pressure left out of the reserve tank;
- Uncouple the hose between the vesselbottom and the control cabinet;
- Clean filter element in the air filter (21);
- Set the filter element into the water filter (20);
- Ensure dry storage of the machine !

3. Information for Practice

This chapter will help you to use the machine better for all the different possible works.

3.1. Blasting result – optimization of the parameter

The setting of the machine depends on the result which is needed. The following settings influence the blasting result and have to be conformed to the result:

- blasting pressure;
- blasting hose;
- blasting nozzle;
- blasting media;
- quantity of blasting mixture and water.

There is no general solution for the setting because of always different working conditions. But there are some rules to exclude typical mistakes at the setting and to find a close optimized solution for the setting.

3.1.1. Soft blasting

The target for soft blasting is to have an equable and clean result without respectively with low damage of the surface.

The most unnecessary mistakes during soft blasting are:

- Selection of the blasting media (hardness, grain),
- Setting blasting mixture consumption,
- Setting blasting pressure,
- Combination of blasting hose and blasting nozzle and
- Handling of the blasting nozzle.



See table at chapter 3.2. for the best initial values.

Information for the best handling of the blasting nozzle, look at chapter 3.3..

3.1.2. Power blasting

The target for power blasting is to have a maximum on abrasion power.

This means not only that it is enough to have plenty of air volume and the right blasting media and setting for blasting mixture, but also to have low power losses.

Needless power losses arise when:

- The cross-section of the air hose between air-compressor and machine or the cross-section of the blasting hose is too small;
- The hoses are too long or have too much arcs;
- The nozzle has a wrong cross-section or –shape;
- The blasting mixture or the setting of blasting mixture is wrong.



- Examples for the initial setting, see table at chapter 3.2.

3.2. Adjustments and settings

In the first column of the first table „Material of object to be blasted“ the work to be done is to be stipulated. Following this, the approximate values for the selection of the blasting mixture, the required volume of blasting mixture, the pressure at the machine, the diameter of the blasting nozzle and of the blasting hose may be taken from the respective line.

After selecting the settings and the blasting nozzle by means of the first table you have to select the right air-compressor size, air hose between compressor and machine and the blasting hose size for the blasting nozzle by using the information shown in the second table.

The data in the tables are approx. values only and may differ from case to case.

Table 1: Directional data for settings

Material of the object to be blasted	Type of blasting media	Volume of blasting mixt. lt. per min	Blasting pressure bar	Blasting nozzle mm
Softest cleaning	a)	0,4 / 0,6 / 0,8 / 1,0	0,5 to 1,5	8 to 10
Soft cleaning	a)	0,6 / 0,8 / 1,0 / 1,5	0,5 to 2,0	6 to 8
Cleaning	a) b)	0,6 / 0,8 / 1,0 / 2,0	1,0 to 5,0	10 to 12
Blasting up to 5 m ³ /min	b) c)	2,0 / 3,0	to 10,0	10 to 12
Blasting up to 7 m ³ /min	b) c)	3,0 / 4,0	to 10,0	12 to 14
Blasting up to 10 m ³ /min	b) c)	4,0 / 5,0	to 10,0	14 to 16
Blasting up to 15 m ³ /min	b) c)	4,0 / 5,0 / 6,0	to 10,0	14 to 16

Information to the table 1**Column 2 „Type of blasting media“**

- a) Stone dust, calcite powder, basalt, finical and soft blasting media without sharp edges resp. soft media upto 0,4 mm and with a hardness upto 4 Mohs.
- b) Stone dust, glas powder and other fine blasting media upto 0,8 mm and a hardness upto 8 Mohs.
- c) Slag, granite powder, garnet and other blasting media upto 1,5 (2,0) mm and with hardness upto 8 (9) Mohs.
- d) Sodium bicarbonate, lime (suitable for the removal of paint coat without damaging the metallic surface) and other fine and soft blasting media of a very low hardness.



- In order to ensure a good flow of the blasting mixture it is recommended to use a blasting mixture containing superfines (disadvantageous e.g. a grainage from 1 to 2 mm; better: e.g. 0,4 to 2,0 mm).
- To get more soft cleaning, you may have to use extra water (handwheel „Z“ – equipment 507).

Column 3 „Volume of blasting mixt.“

- For cleaning, always test soft blasting media first.
- The blasting mixture is already mixed with 20% water. If you need more water for soft cleaning, you may have to use extra water (handwheel „Z“ – equipment 507).
- For cleaning, the percentage of water may be increased in the case of machines with dosing facility for extra water (with dosing equipment ZW (506) resp. with handwheel „Z“ (507)) to achieve an optimum result in a still more gentle way.

Column 4 „Blasting pressure“

- For cleaning, always test with a low blasting pressure first.
- The blasting pressure at the machine and at the blasting nozzle may differ because of different length and different diameter of the blasting hoses.

Table 2: Max. compressor size required as a function of the blasting nozzle

Diameter blasting nozzle	mm	6	8	10	12	14	16
Compressor output	m ³ /min	1,8	3,2	5,0	7,2	9,8	12,8
Blasting hose and	mm	13/7; 19/7	19/7; 25/7	25/7; 32/8	32/8	32/8; 49/8	32/8; 49/8
Compressed-air hose	Zoll	1/2; 3/4	3/4; 1	1; 5/4	5/4	5/4; 1 1/2	5/4; 1 1/2



- The shorter the hose and the bigger the diameter of the hose, the lower is the loss of blasting power. (This concerns the air hose between the compressor and the machine and the blasting hose).

3.3. Blasting nozzle and operating

The nozzle: Standard nozzles are Cylinder- and Venturi-nozzles, but the Venturi-nozzle produces a higher speed of the blasting mixture at the nozzle. The result of the higher blasting mixture speed is a higher production efficiency of blasting power (upto 30%).

Also long blasting nozzles have upto 20% more blasting power in comparison to short nozzles.

B. Handling of the blasting nozzle: This is not a question of the machine or the equipment, but of the training of the operator. A well trained operator with experience get up to 50% more production efficiency than a operator without training.

The first step to get the maximum blasting performance is to have a good planning, the right blasting mixture and the right setting of the machine.

After planning, the operator has to know which result is required, so that the operator knows how to handle the nozzle.

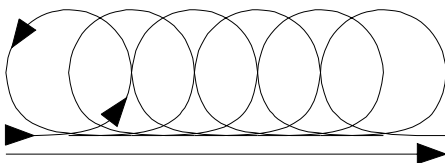

Chapt. 3, Figure 3: movement of the nozzle

Movement of the nozzle

The best way to move the blasting nozzle on large objects is to circulating and side longe the nozzle at the same time. If you don't circular the nozzle, the surface will look unintegrated.



- The faster the circulating and the side longe, the lower the wear on the surface.

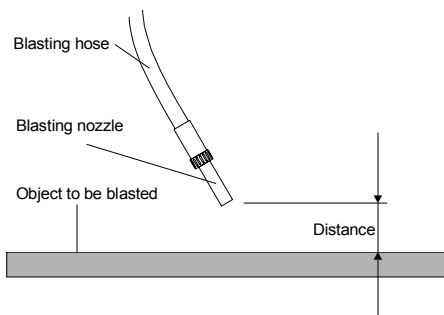

Chapt. 3, Figure 1: distance of the nozzle

Distance of the nozzle

The normal distance between object to be blasted and blasting nozzle is approx. 20 to 25 cm.

One possibility to influence the aggressiveness of the blasting process, is to increase the distance between object and blasting nozzle.



- The nearer the blasting nozzle to the object, the stronger the aggressiveness of the nozzle and the smaller the surface simultaneously treated.

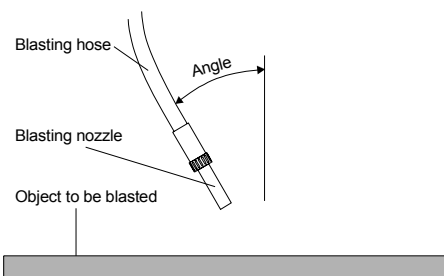

Chapt. 3, Figure 2: angle of the nozzle

Angle of the nozzle

The normal angle between object and blasting nozzle is 20 to 45°.

One possibility to influence the aggressiveness of the blasting process, is to increase the angle between object and blasting nozzle.



- The smaller the specified angle to the object, the stronger the aggressiveness of the nozzle and the smaller the surface simultaneously treated.

4. Maintenance

In order to ensure a correct maintenance of the machine it is compulsory that maintenance is performed only after having read these instructions and by trained personnel.

4.1. Maintenance work

	look at section
Daily before connecting the machine	
<ul style="list-style-type: none"> • cleaning of compressed-air connections • cleaning of water connections 	--- ---
Weekly	
<ul style="list-style-type: none"> • equipment cleaned externally • cleaning of compressed air und water filter • check gaskets of connecting couplings; if necessary, replace gaskets 	--- 4.2. ---

Inspection I

- check non-return valves and clean if needed
- check stoppers and counterparts
- check blasting coupling at the machine
- check insulation of electric components incl. cable
- check hoses and couplings (pneumatic compressed-air and pressurized water hoses, air and water couplings)
- check connections and screwings for leakproofness
- check safety check-valve
- check piston pump for leakproofness and slightly grease it
- check dosing valve(s) and clean if necessary
- check manometer(s) for perfect functioning
- functional test of the machine

Inspection II

Includes all items of inspection I; in addition:

- replace filter elements of compressed-air and water filter
- replace dirty and bucked pneumatic hoses
- dosing valve(s) to be cleaned
- check electric connections for corrosion
- check function of control valves
- clean and check non-return valves at compressed-air connection
- check vessel for leakproofness
- grease hinges, spring in safety check valve and locks

In one-shift-operations the inspection I and inspection II are to be carried through at intervals of 3 to 6 months.

Any occurring troubles, faults etc. are to be eliminated immediately by adequately trained personnel; before starting the machine again, any defective parts are to be replaced by new original parts.



- Before beginning any maintenance work, the power, compressed-air and water connections are to be detached and the machine is to be depressurized.
- The machine must be protected from re-start.
- Repairs and the inspection I and II may be carried through by adequately trained personnel only, being at disposal via the torbo-trading partners.
- For mobile units with compressors the inspections of the respective manufacturer must be adhered to for maintenance at the compressor or chassis respectively.
- For a safe operation and a long service life of the machine and its accessories, it must be adhered to the cleaning and maintenance advises shown in the instructions for operation.



4.2. Information to the weekly maintenance

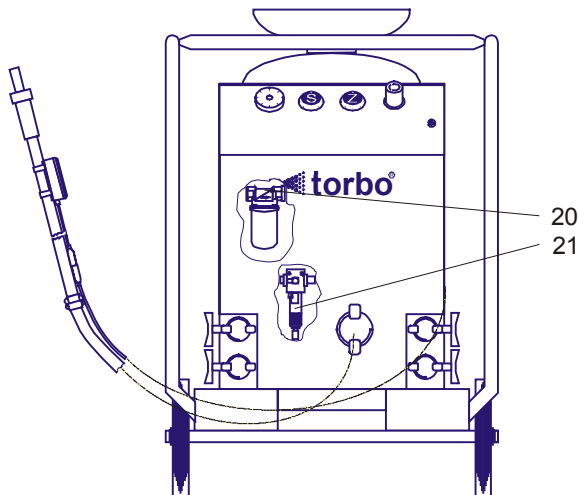

Chapt. 4, Figure 1: Cleaning

Water filter (20)

To clean the water filter proceed as follows:

- Open the filter by undoing the screws at the upper side of the filter;
- Remove filter element from container and clean it with compressed air or water or resp. replace the filter element;
- Clean container with water;
- Insert filter element again – look at the gasket at the upper side;
- Tighten container with filter element and gasket by screwing.



Caution

- Switch off the machine and protect the machine from re-start.
- Look for the right position of the gasket.

Compressed-air filter (21)

To clean the compressed-air filter proceed as follows:

- Screw off container (turn left);
- Screw off filter element and clean with compressed air; supersede if necessary;
- Screw in filter element again;
- Clean container with water;
- Screw in container again (Caution for O-ring at the container!).



Warning

- Before beginning, the power, compressed-air and water connections are to be detached and the machine is to be depressurized.
- The machine must be protected from re-start.

5. Trouble-shooting

To find the reason for a possible trouble please proceed as follows:

1. Begin at „Start“ in the diagram and answer to one question after the other.
2. If a possible source of trouble is found the corresponding questions under this item has to be checked at the machine.
3. If the answer to the first question is „Yes“, the next item has to be checked as long as one item has to be answered with „No“.
4. This reason for the trouble has to be repaired.

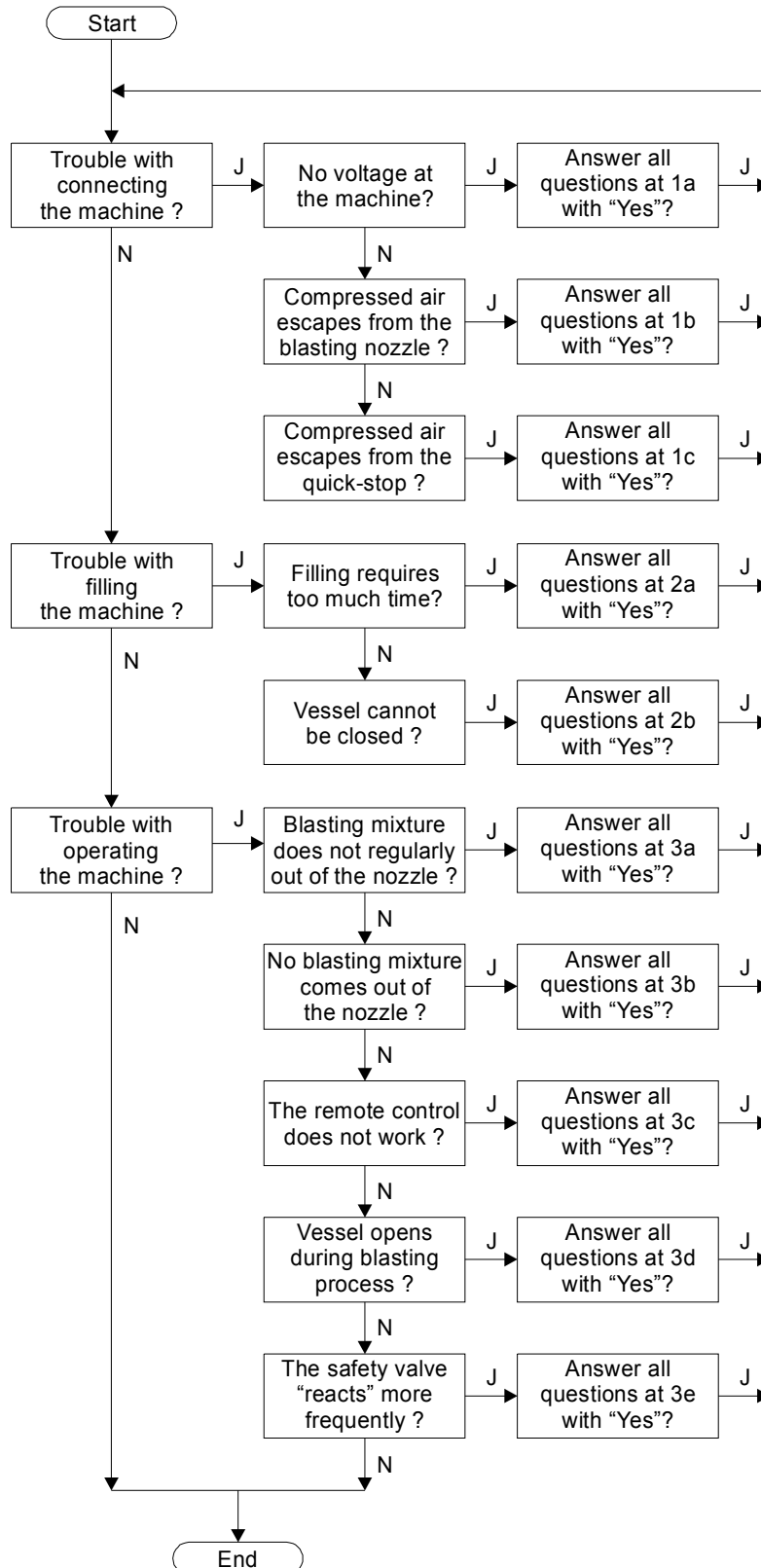

Questions 1a

- Are the pole tongs at the connecting cable clean ?
- Does main switch light up ?
- Does LED at socket-outlet show green light ?
- Is interlock of EMERGENCY-OFF-switch deactivated ?

Questions 1b

- Is the ball valve „P“ for the compressed air control closed ?

Question 1c

- Is the ball valve „P“ for the compressed air control closed ?
- Are the plugs in the actuating units quick-stop and compressed air o.k. ?

Questions 2a

- Is the abrasive dry ? (applicable only to machines without flushing equipment in the sieve top – 203 or 205)
- Are the flushing nozzles in the sieve top actuated and does water penetrate from the nozzle ?
- Is the blasting mixture granulate correct ?

Questions 2b

- Is the ball valve „P“ for the compressed air control closed ?
- Has the vessel lock been relieved from blasting mixture ?
- Is the rubber seal on the locking plate o.k. ?
- Has the handwheel „S“ been set on „D“ resp. on maximum value ?
- Is the pressure control open ?
- Has the overflow been closed ?
- Do the proximity switches of the piston pump light up alternatingly ?
- Is the locking stopper of the switching unit `blasting mixture` o.k. ?

Questions 3a

- Has the blasting mixture got a sufficient percentage of superfines ?
- Has the cross-section of the blasting hose and the nozzle diameter been chosen correctly ?
- Is the interior of the blasting hoses and blasting nozzle free ?
- Is the non-return valve in the pressure vessel o.k.?

Questions 3b

- Has the machine been set for blasting ?
- Is the blasting mixture fine enough ?
- Does blasting mixture penetrate from the vessel, when the blasting mixture hose has been uncoupled ?
- Does the switching unit `blasting mixture` open ?
- Have the pneumatic hoses of the switching unit been checked ?

Questions 3c

- Does the main switch light green ?
- Are the extension cables of the remote control checked ?
- Are the plugs at the control valves for the switching units checked ?
- Are the coils at the control valves checked ?
- Is the remote control checked ?

Questions 3d

- Does the air pressure connected at the machine exceed 2 bar ?
- Is the ball valve at the overflow closed and leakproof ?
- Is the filter element in the air filter controller checked and clean ?
- Is the vessel locking plate at the vessel lock checked ?
- Is the plug in the switching unit `blasting mixture` checked ?
- Is the non-return valve in the vessel checked ?

Questions 3e

- Is the connected water pressure (see manometer) less than 12 bar ?
- Has the control pressure (see manometer) been set correctly (between 11 and 12 bar) ?

6. Technical Data

6.1. General Data

		torbo® LOC080	torbo® LOC120
Volume of vessel	l (dm ³) / Cu. ft	80 / 2,8	120 / 4,2
Control pressure (max.)	bar / PSI	12 / 170	12 / 170
Weight (empty)	kg	160 – 200	180 – 220
	lbs.	350 – 440	400 – 940
Dimensions (height x width x depth)	mm	1.130 x 1.200 x 800	1.220 x 1.200 x 800
	inches	45 x 48 x 32	49 x 48 x 32
Size Air-connection	mm / inches	a) 19/7 / 3/4 b) 25/7 / 1	a) 19/7 / 3/4 b) 25/7 / 1
Air Connection (min. – max.)	m ³ /min	a) 2,0 – 5,0	a) 2,0 – 5,0
	Cu. ft. per min.	70 – 175	70 – 175
		b) 2,0 – 10,0	b) 2,0 – 10,0
	bar	4,0 – 10,0	4,0 – 10,0
Connected power	PSI	56 – 140	56 – 140
	Volt / Watt	12 / 1,2	12 / 1,2
Pressurized water (min. - max.)	Bar	1,0 – 12	1,0 – 12
	PSI	10 – 170	10 – 170
Blasting hose connection	mm / inches	32 / 1 1/4	32 / 1 1/4
Consumption of blasting media (min. – max.)	l/min	0,32 – 2,4	0,48 – 4,8
	cu. ft. per min.	0,01 – 0,08	0,02 – 0,17
Blasting time (100% period of use)	Std. / h	3,6 – 0,5	3,8 – 0,4
Average blasting time per filling	Std. / h	1,0	1,5
Standard blasting mixture	Strahlmittel / Wasser	80 % / 20 %	80 % / 20 %
Water consumption during blasting	l/min.	0,08 – 0,6	0,12 – 1,2
	gals. per min.	0,02 – 0,15	0,03 – 0,30
Sieve top for:			
Dry blasting media		standard	standard
Wet blasting media		N / A	Verfügbar
Fast filling device		N / A	N / A
At the remote control			
Safety magnetic-switch		standard	standard
Function „blasting“		standard	standard
Function „cleaning“		N / A	N / A
Function „drying“		N / A	N / A
At the machine			
Dosing for blasting mixture		standard	standard
Function „extra water“		obtained	obtained
Setting for extra water		obtained	obtained
Setting blasting pressure		standard	standard
Setting control pressure		standard	standard
Emergency-switch		standard	standard
Quick-stop (0 bar at the nozzle)	3 sec. per 100 m blasting hose	obtained	obtained
Safety air reserve tank		standard	standard
Filter for water and switching-air		standard	standard

6.2. Wiring scheme

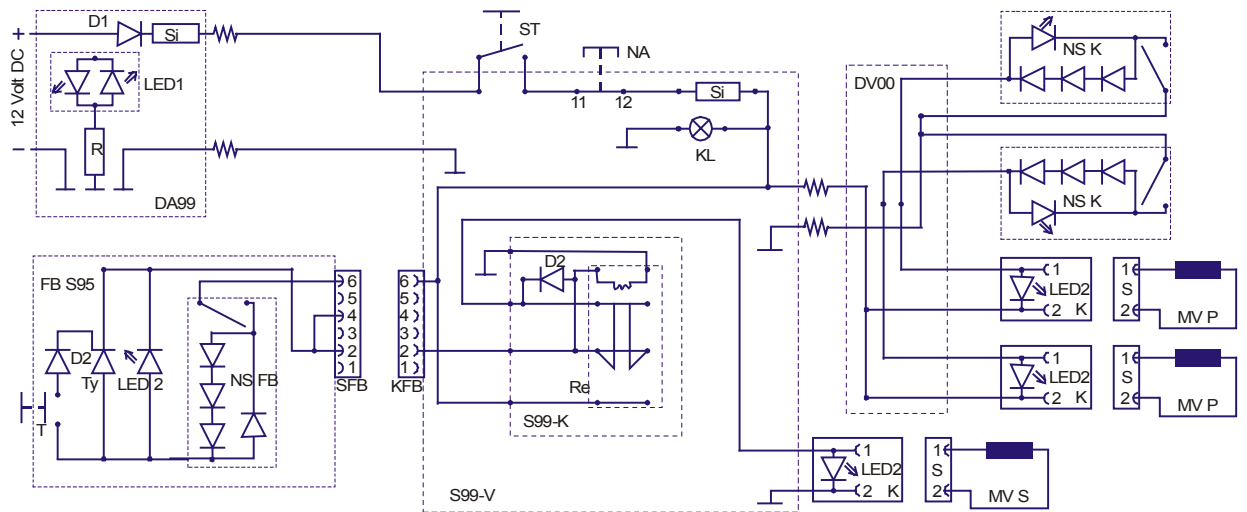

Legend to the switch-plan

B1	Blue
B2	Brown
D1	Diode 1 N 5400
D2	Diode 1 N 4007
DA99	Power socket
DV00	Powerbox DV00
FB S95	Electric remote control
K	Coupling control valve; IP 65
KFB	Coupling coupling remote control IP 65
KL	Lamp
LED1	LED (red/green), 4,5 V, 11 mA
LED2	LED (green), 12 V, 11 mA
MV P	Magnetic coil, control valve, pump; 12 V DC, 7,5 W, 0,62 A
MV S	Magnetic coil, control valve, switching units; 12 V DC, 7,5 W, 0,62 A
NA	Emergency-off; switch type RPV / KC / I; ICE 947 / EN 60 947 / VDE 0660 Vi 500 V; IP 65
NSFB	Proximity switch, remote control FB S99; 10 - 240 V DC/AC, max. 1A resp. 50 W / 50 VA
NSK	Proximity switch, pump; 10 - 240 V DC/AC, max. 1A resp. 50 W / 50 VA
R	Resistor 560 Ohm, 1/4 W
Re	150 V DC/AC, 1,25 A, 30 W / 50 VA; relay, 2xUM
S	Plug control valve (Plug at coil MV PV L, MV PV R resp. MV SV)
S99-K	Controllboard S99
S99-V	Powerbox S99
SFB	Plug remote control FB S99; IP 65 in closed state acc. to DIN 40 050
Si	Fuse, Poly-Switch, 50 V, $I_{IH} = 1,6$ A (= nominal current), $I_S = 2,4$ A
ST	Push-button, Watertank
T	Push-button; 42 V, 100 mA (max. 3 VA); IEC 529
Ty	Thyristor C 106

6.3. Hydraulic (water) scheme

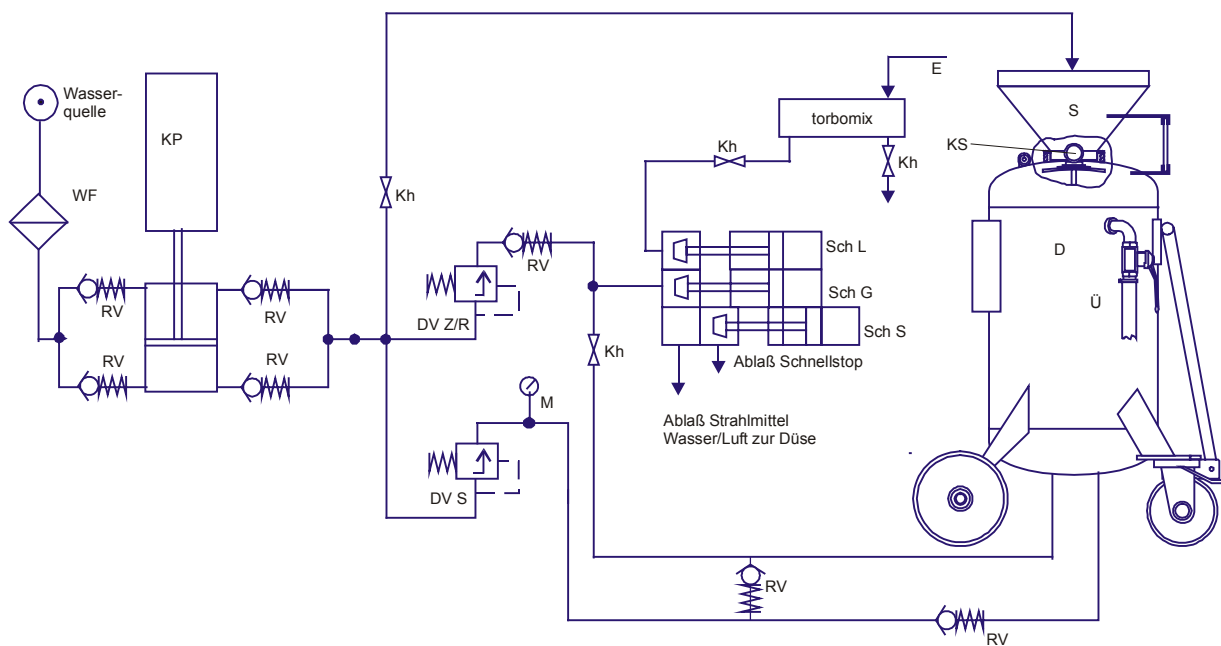

Legend to the hydraulics-plan

Ablaß	Outlet
Ablaß Schnellstop	Drain quickstop
Ausgang Strahlmittel/ ...	Outlet blasting mixture, water, air to the nozzle
D	Pressure vessel (vessel for blasting media and water)
DV S	Dosing valve – volume of blasting mixture
DV Z	Dosing valve – volume of water to be added
E	Inlet torbomix
K 1 – 2	Ball valve (torbomix)
KP	Piston pump
KS	Vessel locker
MK	Gauge – control pressure
MW	Gauge – water admission pressure
RV	Non-return valve
Sch G	Switching unit – blasting mixture
Sch L	Switching unit – compressed air
Sch S	Switching unit – quick stop
Ü	Overflow
Wasserquelle	Water source
WF	Water filter

6.4. Pneumatic scheme

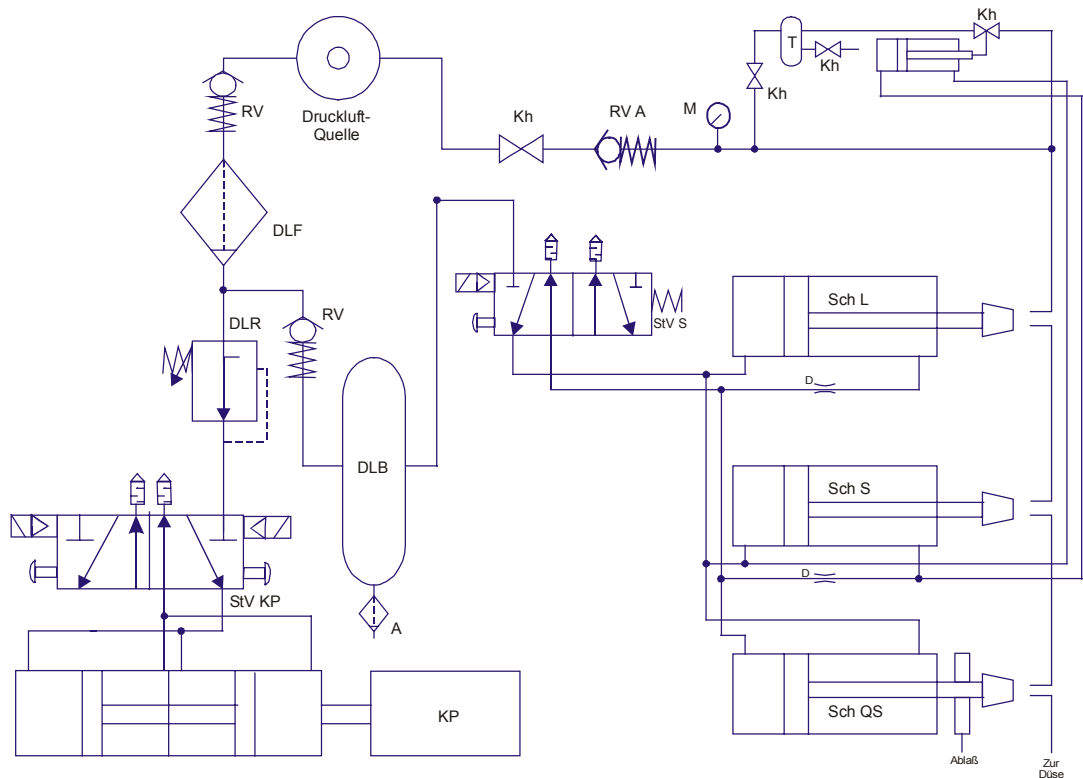

Legend to the pneumatic scheme

A	Outlet valve
D	Throttle
DLB	Air reserve tank
DLF	Compressed air filter
DLR	Compressed air control
Druckluftquelle	Compressed air source
Kh	Shut-off valve
KP	Piston pump
M	Pressure gauge
RV	Non-return valve
RV A	Non-return valve for operating air (blasting air)
RV St	Non-return valve for control air
Sch L	Switching unit compressed air
Sch QS	Switching unit quick stop
Sch S	Switching unit blasting mixture
StV KP	5/3 port valve piston pump
StV S	5/3 port valve switching units
T	Tank torbomix
Zur Düse	To the nozzle

Headword contents

Code of Practice, 5

Connection

- Blasting hose, 10, 21, 26
- Compressed-air, 10, 20, 21, 26
- Electrical, 10, 26
- Remote control, 10, 11
- The Machine, 13
- Water, 10, 26

Hose

- Blasting, 10, 21, 26
- Compressed-air, 10, 20, 21, 26
- Overflow, 10

Dangers

- dusts, 8
- electric energy, 8
- noise, 8
- pneumatic energy, 8
- special hazards, 8

Data of the Machine, 5

Dosing, 11

Filling the machine, 14

Frost precaution in winter, 18

Information for Practice, 19-21

Information to the weekly maintenance, 23

Instructions

- Basic, 6
- Basic Safety, 7
- Operation, 10, 13
- Transport, 12

Maintenance, 9, 22

Normal operation, 14

Operation

- Components, 11
- Normal, 14
- Remote control, 16
- Setting, 15, 19, 20

Practice, 19-21

Setting the machine, 15

Switching off the machine, 17

Technical data, 26

- General, 26
- Hydraulic scheme, 28
- Pneumatic scheme, 29
- Wiring scheme, 27

Trouble-shooting, 24

